

39

(12) **EUROPEAN PATENT APPLICATION**

(21) Application number: 86303039.1
 (22) Date of filing: 22.04.86

(51) Int. Cl.: **C 12 N 15/00, C 12 C 11/00,**
C 12 P 7/06, C 12 P 21/02
// C12N9/38

<p>(30) Priority: 22.04.85 GB 8510219</p> <p>(43) Date of publication of application: 12.11.86 Bulletin 86/46</p> <p>(84) Designated Contracting States: AT BE CH DE FR GB IT LI LU NL SE</p>	<p>(71) Applicant: Delta Biotechnology Limited, 137 High Street, Burton on Trent DE14 1JZ (GB)</p> <p>(72) Inventor: Hinchliffe, Edward, 44 Hall Road Rolleston-on-Dove, Burton on Trent East Staffordshire (GB) inventor: Kenny, Enda, 11 Rouen Way, Ashby-de-la-Zouch Leicestershire (GB)</p> <p>(73) Representative: Collier, Jeremy Austin Grey et al, J.A.Kemp & Co. 14, South Square Gray's Inn, London WC1R 5EU (GB)</p>
---	---

(54) **Process for the isolation of fermentation products.**

(57) The invention provides a process for the production of ethanol and a protein or peptide which is heterologous to yeast which comprises fermenting an aqueous carbohydrate-containing medium with an industrial yeast strain which has been genetically modified to be capable of expressing a heterologous protein or peptide, under conditions such that the yeast multiplies but no expression of the said heterologous protein or peptide takes place, recovering the ethanol so-formed, inducing expression of the said protein or peptide by the yeast, and obtaining the said heterologous protein or peptide therefrom. The process may be applied to the industrial production of alcoholic beverages such as beer or distilled alcohol. The yeast inevitably obtained as a by-product in the process has improved value because it provides a source of the heterologous protein or peptide. Heterologous protein and peptides which may be produced by the new process include enzymes such as beta-lactamase, beta-glucanase and beta-galactosidase and proteins of therapeutic value such as human serum albumin.

EP 0 201 239 A1

- 1 -

PROCESS FOR THE ISOLATION OF FERMENTATION PRODUCTS

This invention relates to the isolation of fermentation products.

In the manufacture of alcohol by fermentation, sugars in aqueous solution are converted into ethanol by fermentation with yeast. The yeast grows during the fermentation and although a small proportion of the yeast may be used in a subsequent fermentation process, the remainder of the yeast constitutes an excess that must be disposed of. While this excess yeast has some uses, e.g. in animal feedstuffs and the manufacture of yeast extracts, the quantity of excess yeast produced is large and its market value is relatively low.

Large scale fermentations of this kind fall into three broad categories:

(1) Fermentations in which the fermented aqueous medium obtained is the desired end product. Into this category fall ordinary brewing processes for the production of beer (a term which, as used herein, includes ales, stouts, lagers and other fermented drinks based on malt), cider and other fermented drinks.

(2) Fermentations in which the desired end product is a distilled drinkable alcoholic concentrate. Into this category fall fermentations for production of whiskies, brandies and other spirits, and alcohol for use in fortifying other drinks.

(3) Fermentations for the production of alcohol for industrial use. Into this category fall fermentations carried out in some countries on a large scale for the production of fuel alcohol, and fermentations of certain industrial effluents, e.g. from paper pulp manufacture. The production of excess yeast is a characteristic of all these industrial processes.

Considerable interest has been shown in recent

- 2 -

years in the genetic modification of microorganisms so that they become able to produce heterologous proteins and peptides, that is to say proteins and peptides which are not produced by their natural genetic constituents. A variety of microorganisms have been used for such genetic manipulation, and, amongst these, yeasts have attracted a certain amount of interest. However, yeasts used in laboratory experiments are not normally the same as the yeasts used in large scale industrial fermentations involving the production of alcohol, and the conditions of growth of yeast in the laboratory are very different from those encountered by yeasts in an industrial alcoholic fermentation.

The yeasts are a group of lower eukaryotic micro-organisms showing biological and biochemical diversity. In common usage the term "yeast" is used to describe strains of Saccharomyces cerevisiae that have commercial value in baking, brewing and distilling. Related yeasts are used in wine making and sake brewing, as well as in the production of fuel alcohol from sucrose or hydrolysed starch, and in the treatment of effluents.

All the yeasts used for brewing, baking and distilling may be taxonomically classified as Saccharomyces cerevisiae. Included within this classification are the top fermenting ale yeasts (S. cerevisiae) and the bottom-fermenting lager yeasts (S. uvarum or S. carlsbergensis).

In a strict sense the term "brewers yeast" differentiates yeast used in brewing from all other yeasts in that it is a yeast strain which is used to make beer, i.e. a strain of yeast used currently in a beer manufacturing process. Such yeasts must be able to produce a palatable acceptable beer by their fermentative action upon hopped or unhopped malt extract (brewers wort). The primary products of this fermentation are

- 3 -

ethanol and carbon dioxide, which are essential constituents of beer. However, not all yeasts belonging to the species S. cerevisiae are capable of fulfilling these requirements. Indeed, the critical factor in this respect is believed to be the ability of the yeast strain to form in subtly balanced proportions, quantitatively minor metabolic products such as esters, acids, higher alcohols and ketones. A yeast may be unsuitable for brewing because one or more of these minor metabolic products is produced in excessive amounts, either in absolute terms or relative to one another. (Rainbow, C.A., 1970, In "The Yeasts", eds, Rose, A.H. & Harrison J.S. Vol. 3, p. 147).

In a general sense brewers yeast is differentiated from other yeasts by the properties which it possesses. Most strains of industrial yeast, unlike laboratory yeast, are incapable of undergoing mating; they are said to be homothallic. Industrial yeasts are usually aneuploid or polyploid, and there is therefore a reduced incidence at which gene mutations are phenotypically detected. Most polyploid strains do not sporulate or they produce spores of very low viability, thus frustrating any meaningful genetic analysis. These factors together tend to confer a measure of phenotypic stability on industrial yeasts which may contribute to their selection for industrial application. Similarly gene dosage which is associated with high ploidy may contribute to the general fitness of such strains for fermentation as compared to haploids and diploids, which generally ferment poorly.

In addition, brewers yeasts have certain technological behaviour which equips them well for interacting with their normal environment, i.e. brewers' hopped wort, for example the ability to ferment at the top of the fermentation vessel (ale yeast) or the bottom of the vessel (lager yeast).

- 4 -

In European Patent Application No. 84308981.4 in the name of Bass PLC, published under No. 147198 there is described and claimed a process for the production of ethanol and a protein or peptide which is heterologous to yeast which comprises fermenting an aqueous carbohydrate-containing medium with a yeast strain which has been genetically modified to be capable of expressing a heterologous protein or peptide, recovering the ethanol so formed, and obtaining the said heterologous protein, or peptide from the fermentation products.

The invention of that Application is based on the discovery that it is possible to use, in an industrial fermentation involving the production of alcohol, genetically modified yeast capable of expressing a heterologous protein or peptide. Surprisingly, it was found that the use of such yeasts is compatible with industrial or brewery fermentation conditions. This means that the excess yeast obtained in the fermentation provides a source of the heterologous protein or peptide and thus has much enhanced industrial value. Further, since the alcohol product remains the principal objective of the fermentation, and the conventional equipment can largely be used with little alteration, the additional cost of producing the higher value yeast product is small, so that the new process may provide an economically viable route to heterologous proteins or peptides which, although valuable, do not command a premium price.

When the process of our aforesaid Application is operated to produce an aqueous potable liquid such as beer, at the end of the fermentation, the fermented liquid is separated from the yeast (and normally any other solid material present in the fermented medium). In these circumstances, it is clearly desirable, and indeed normally essential,

- 5 -

that the fermented liquid shall not contain the heterologous protein or peptide, since it is normally unacceptable for the heterologous protein or peptide to be present in a liquid which is to be drunk.

5 In the said Application it is stated that, in such circumstances, the heterologous protein or peptide may be obtained from the yeast cells.

 In the process of the present invention, the fermentation is carried out under conditions such that the yeast reproduces in the usual way but little or no heterologous protein or peptide is produced. Then, normally after the yeast has been separated from the fermented liquid, expression of the heterologous protein or peptide is induced, and the protein or peptide so obtained is separated from the yeast. Operation in this manner avoids the risk that the fermented liquid itself may become contaminated with the heterologous protein or peptide. It also avoids any risk of the alcohol production being compromised by the presence of the heterologous protein or peptide during the fermentation, and in particular by the synthesis of the protein or peptide adversely affecting the ability of the yeast to produce alcohol by fermentation.

25 According, therefore, to the present invention, a process for the production of ethanol and a protein or peptide which is heterologous to yeast comprises fermenting an aqueous carbohydrate-containing medium with a yeast strain which has been genetically modified to be capable of expressing a heterologous protein or peptide under conditions such that the yeast multiplies but no expression of the said heterologous protein or peptide takes place, recovering the ethanol so formed, inducing expression of the said protein or peptide by the yeast, and obtaining the said heterologous protein or peptide therefrom.

- 6 -

A variety of different systems have been described for expressing heterologous genes in yeast. In most cases these systems depend upon the growth of new cell biomass under conditions which facilitate the efficient transcription and translation of the gene of interest, so as to produce the relevant protein or peptide. However, with some expression systems, manipulation of the contents of the growth medium influences the expression of the heterologous gene. In such cases new cell biomass can be grown without the concomitant production of the heterologous protein or peptide, and gene expression can then be induced by transferring the yeast cells to conditions which favour heterologous gene expression.

It is necessary in the present invention to choose a gene expression system compatible with the contemplated ethanolic fermentation. Some known systems are inappropriate. For example, glycolytic gene promoters of yeast can be used to induce the production of heterologous proteins in yeast cells. Large amount of yeast biomass can be obtained by growth in a medium containing a non-fermentable substrate as a sole carbon source; gene expression can then be induced by the addition of glucose which stimulates the transcription of the glycolytic gene promoter, e.g. PGK (Kingsman and Kingsman, 1982, European Patent Application, 0 073 635, Expression Vectors). A similar system which utilizes the Acid Phosphatase gene (PH05) promoter can be used for inducing gene expression under conditions of inorganic phosphate starvation (Hinnen et al, 1983, European Patent Application, 0 100 561, Yeast hybrid vectors and their use for the production of polypeptides). These known systems for inducing gene expression in yeast require, however, the use of a defined growth medium upon which to produce large amounts of

- 7 -

cell biomass. Furthermore, in the case of the glycolytic gene promoter, growth upon a non-fermentable carbon source requires the presence of oxygen. Thus neither system is generally applicable to fermentations by brewing yeast, 5 since the brewing process is substantially or in part anaerobic (oxygen free) and the growth medium is brewers wort, which is a relatively complex mixture of sugars which includes maltose and glucose.

The induction of heterologous gene expression in 10 brewing yeast must be compatible with the demands of the beer fermentation if it is to be used in the present invention. In this respect it is necessary to induce gene expression with an effector or condition which is normally not present in brewers wort and beer. Known gene expression systems for 15 inducing the production of heterologous proteins and polypeptides in yeast and suitable for use in the present invention, include: (i) the heat shock promoter (HSP90) of yeast (Finkelstein, 1983, WO 84/04535, Heat regulated production of selected and fused proteins in yeast) and (ii) 20 the GAL1 promoter of yeast (Botstein et al, 1984, UK Patent Application GB 2,137,208A, The use of the GAL1 promoter). These systems utilize heat and galactose, respectively, to stimulate gene expression and each could be applied in the present invention. The application of a galactose regulated 25 system is particularly useful since brewers' wort does not usually contain sufficient galactose to effect the expression of a galactose regulated promoter. Consequently, such galactose-regulated gene expression systems are not functional in brewing yeast during the course of a beer fermentation.

- 8 -

The yeast strain used in the new process must, of course, be suitable for the type of industrial fermentation contemplated. This objective may be secured by carrying out the genetic modification on a yeast strain which is known to
5 have the desired characteristics, since it has been found that the desirable characteristics which make a yeast strain suitable for a particular type of industrial fermentation can be maintained during the genetic modification. For example, where the fermentation is one for producing beer, the yeast
10 strain chosen for genetic modification is preferably a known strain of brewers' yeast currently used in such fermentations. As already noted, such industrial strains of brewers yeast have characteristics different from those of "laboratory yeast", including in particular the ability to ferment hopped
15 brewers wort.

Brewers wort is essentially a hot water extract of malted barley or other grains prepared by steeping and germination and flavoured with hops. The most important parameters with respect to yeast growth and metabolism are
20 carbohydrate and nitrogen (and amino acid) composition. These vary from country to country and brewery to brewery, see, e.g., "Malting and Brewing Science", Vol. 2, Hopped Wort and Beer; by Hough, J.S., Briggs, D.E., Steven R. and Young, T.W., 1982, Chapman and Hall, London and New York,
25 p.456-498. In general it may be said that brewers

- 9 -

wort contains 5 to 10 g of total fermentable sugars per 100 ml of wort, at least half of which is maltose.

Additional factors which influence yeast growth and performance are: (1) Growth factors. These include substances such as biotin, thiamine, riboflavin, pyridoxine, pantothenic acid and nicotinic acid. In general brewers wort is a rich source of these factors, which are depleted during yeast growth.

10 (2) Minerals. The mineral requirements of brewers yeast resemble those of most living organisms. Brewers wort meets these requirements, supplying trace amounts of metal ions such as iron, potassium, magnesium, zinc, manganese and copper, which are

15 essential nutrients for growth and fermentation.

The most significant difference between a laboratory culture medium and a brewers wort is the sugar composition of the medium. Most laboratory media utilise glucose as the chief source of

20 carbohydrate, whereas maltose is the chief fermentable constituent of wort.

Brewery fermentations normally take the form of anaerobic (oxygen free) fermentations. However, oxygen is a prime requirement for yeast growth in the

25 initial stages of fermentation. Most laboratory fermentations are designed to maximise the yeast biomass yield, whereas beer fermentations concentrate upon ethanol yield and product flavour. Thus the inoculation rate ("pitching rate") of a beer

30 fermentation is higher than would normally be used in the laboratory. Consequently, the number of cell doublings (cell generations) is reduced to between 2 and 4 per fermentation.

The fermentation of beer wort is normally

35 carried out at a temperature within the range of 8 to 25°C, a temperature at the upper end of this

- 10 -

range, e.g. 15 to 25°C being used when the product is ale, and a temperature of e.g. 8 to 15°C being used where the product is lager. Under laboratory conditions, yeasts are cultivated at significantly higher temperature, e.g. 25 to 35°C.

5 Similarly, where the industrial fermentation is one for the production of alcohol which is separated by distillation, it is necessary to use genetically modified yeast obtained from a strain suitable for such fermentation. In such fermentations, the source of carbohydrates may be, for example, grain, potatoes, cassava, sugar cane, sugar beet or a lignocellulosic material and may optionally have been pre-treated, e.g. by chemical, enzymic or physical methods, to convert cellulose and/or starch therein into fermentable sugars.

The genetic modification of yeast may be effected by the application of known techniques. Suitable methods are described in the literature, and particular methods are given in the Examples below.

20 A wide range of heterologous proteins or peptides may be expressed in the yeast. By way of example mention may be made of enzymes such as beta-lactamase, beta-glucanase, and beta-galactosidase. Other useful heterologous proteins and peptides include materials of human origin and/or useful in therapy, such as human serum albumin and immunoglobulins. Methods are described in the literature for the genetic modification of microorganisms to enable them to express such proteins and peptides.

30 The following Examples illustrate the invention in more detail. The eight figures of the accompanying drawings show respectively:

1. Construction of plasmid pEHB11
- 35 2. Oligonucleotide sequence of the HSA primer
3. DNA sequence of the HSA cDNA gene

- 11 -

4. 5' Non-coding region modification and signal peptide sequence excision
5. Construction of an "authentic" HSA cDNA (MET-HSA)
6. Plasmid pEK113
- 5 7. Construction of plasmid pEHB11-MET-HSA
8. Construction of plasmid pET13:1 MET-HSA

EXAMPLE I

Beta-galactosidase production in Brewing Yeast

Beta-Galactosidase (EC 3.2.1.23) is an enzyme
10 (protein) which hydrolyses the terminal non-reducing
beta-D-galactose residues in beta-D-galactosides such
as lactose. E. coli beta-galactoside is the product
of the Lac Z gene which is located at map position 8
minutes on the E. coli chromosome (Bachmann, B.J.,
15 1983, Microbiological Reviews, 47, p. 180). The
Lac Z gene forms part of the lac operon, which has
played a central role in the elucidation of the
genetic control of gene activity in the prokaryote E.
coli (Beckwith, J., 1972. In "The Operon" p. 11,
20 eds. Miller, J.B. and Reznikoff, W.S., Cold Spring
Harbor Laboratory, Cold Spring Harbor, New York).

In recent years the structural gene for
beta-galactosidase (Lac Z) has been used in DNA
manipulations. It has been shown that the
25 amino-terminal end of the beta-galactosidase protein
is not essential for enzymatic activity (Muller-Hill,
B. and Kania, J., 1974, Nature, 149, p.561). This
has facilitated the construction of many gene
fusions, in which the 5' - coding segment of the
30 Lac Z gene (corresponding to the N-terminal end of
the protein) has been replaced with other DNA
sequences. In these gene fusions, the gene
transcriptional promoter of Lac Z is replaced by
analogous DNA sequences originating from different
35 genes (Casadaban, M.J. et al, 1980, Journal of
Bacteriology, 143, p. 971), but proteins obtained

- 12 -

retain beta-galactosidase activity.

The Lac Z gene of E. coli was one of the first prokaryotic chromosomal genes to be expressed in S. cerevisiae (Panthier, J.J. et al, 1980, Current Genetics, 2, p. 109). In this demonstration the native E. coli Lac Z gene was sub-cloned into a yeast/E. coli shuttle vector (plasmid) and introduced into laboratory strains of yeast which do not possess endogenous beta-galactosidase activity. However, the level of gene expression and thus enzyme production was inefficient using this system. More recently, gene fusions have been constructed in which the transcriptional promoter of the yeast cytochrome C1 gene (CYC1) has replaced that of Lac Z. These CYC1 - Lac Z fusions have been introduced, by transformation, into laboratory strains of yeast, where they have been shown to produce enzymatically active beta-galactosidase (Guarente, L. and Ptashne, M. 1981, Proceedings of the National Academy of Sciences, U.S.A., 78, p. 2199). Detailed analysis of the CYC1 - Lac Z gene fusions has shown that the levels of beta-galactosidase produced in yeast display the pattern of regulation normally seen for cytochrome c (i.e. a reduction of synthesis in cells grown in glucose). (Guarente, L. and Ptashne, M., 1981.) In this way the Lac Z gene has been used to study the regulation of gene expression in both prokaryotes and eukaryotes at the level of DNA transcription.

In the yeast CYC1 gene, DNA sequences which regulate DNA transcription by RNA polymerase II have been located in two regions upstream (5') of the coding sequences for the cytochrome c protein. One of these regulatory sequences is situated close to where transcription initiates; the other is upstream of the initiation region and contains an activation

- 13 -

site which enhances gene expression (UASc) (Guarente, L. and Ptashne, M. 1981; Faye, G. et al, 1981, Proceedings of the National Academy of Sciences, U.S.A., 78, p. 2258). Guarente and co-workers (1982, Proceedings of the National Academy of Sciences, 79, p. 7410) have shown that other genes possess upstream activation sites (UAS), in particular the GAL10 gene of S. cerevisiae. These workers constructed a gene fusion in which the UASc of CYC1 was replaced by the UAS of the GAL10 gene. Furthermore, the gene fusion which retains the promoter (transcription initiation region) of CYC1 is fused to the Lac Z gene of E. coli, such that an enzymatically active beta-galactosidase is produced in yeast transformed with plasmid DNA carrying the hybrid gene (plasmid pLGSD5).

The regulation of genes involved in galactose metabolism in yeast is well understood. The transcriptional expression of three genes (GAL1, GAL10 and GAL7) encoding enzymes required for the metabolism of galactose is dependent upon a transcriptional activator encoded by the gene GAL4 (Oshima, Y. 1982, in "The Molecular Biology of the Yeast Saccharomyces: Metabolism and Gene Expression" eds. Broach, J.R. et al, p.159, Cold Spring Harbor Laboratory, Cold Spring Harbor, New York). The ability of the GAL4 activator protein to promote transcription of these genes is reversibly inactivated by the product of the GAL80 gene, (GAL80 repressor protein). Galactose is thought to bind to the GAL80 repressor protein thereby freeing the GAL4 activator protein to promote transcription of the galactose-specific genes. The GAL10-CYC1 hybrid promoter is subject to induction by galactose in the manner described above (Guarente, L. et al, 1982,

Proceedings of the National Academy of Sciences, U.S.A., 79, p. 7410). Thus beta-galactosidase production is induced by galactose.

5 The production of E. coli beta-galactosidase in brewing yeast

In order to introduce the beta-galactosidase gene of E. coli, expressed from the GAL10-CYC1 hybrid promoter into brewing yeast strain NCYC240, it was necessary to sub-clone the CUP-1 gene present on
10 plasmid pET13:1. The accompanying Figure 1 outlines a scheme whereby the XbaI DNA fragment of approximately 2.85 kilo base pairs carrying the CUP-1 gene was sub-cloned in the single XbaI site of pLGSD5, to form recombinant plasmid pEHB11, containing the GAL10-CYC1
15 promoter.

Brewing yeast strain NCYC240 was prepared for transformation with plasmid pEHB11 by the following procedure. The yeast was grown in 100ml YEP medium (10g/litre yeast extract, 20g/litre peptone)
20 supplemented with 2% w/v glucose to early exponential growth phase; cells were harvested and washed in cold sterile water prior to resuspending in 10mM Tris HCl buffer at pH7.6 containing 1M Sorbitol, 10mM dithiothreitol and 40µg/ml Zymolyase 6000 (Kirin
25 Brewery Co. Ltd) at 30°C. After 1.5 hours incubation the yeast cells are converted into spheroplasts which are harvested by centrifugation and washed three times in 20ml of a solution containing 1M Sorbitol, 10mM CaCl₂, 10mM Tris HCl at pH7.6. Spheroplasts are
30 finally resuspended in 1ml of a solution of 1M Sorbitol, 10mM CaCl₂, 10mM Tris HCl at pH7.6 and 100µl is added to 15µl of plasmid pEHB11. This mixture is incubated at room temperature for 30 minutes prior to the addition of 1ml of a solution of 40% polyethylene
35 glycol 4000, 10mM CaCl₂, 10mM Tris HCl at pH7.6. After 2-5 minutes spheroplasts are harvested by

- 15 -

centrifugation and gently resuspended in 0.5ml NEP Sorbitol medium ($\text{MgSO}_4 \cdot 7\text{H}_2\text{O}$ 2g/l, $(\text{NH}_4)_2 \text{SO}_4$ 2g/l, KH_2PO_4 3g/l, $\text{CaCl}_2 \cdot 2\text{H}_2\text{O}$ 0.25g/l, yeast extract 2g/l, peptone 3g/l glucose 40g/l, 1M sorbitol) and incubated at 28°C for 1 hour before plating in molten NEP Sorbitol supplemented with 3% w/v agar and 0.2mM $\text{CuSO}_4 \cdot 7\text{H}_2\text{O}$. Plates were incubated for 4-6 days at 28°C after which time copper resistant colonies were picked and transferred to NEP supplemented with 2% agar and 0.2mM $\text{CuSO}_4 \cdot 7\text{H}_2\text{O}$. Transformants of NCYC240 harbouring the plasmid pEHB11 were verified by their ability to grow on NEP agar containing 1mM $\text{CuSO}_4 \cdot 7\text{H}_2\text{O}$. In addition, these transformants could be detected by growth on M63 medium containing galactose and the chromogenic indicator Xgal (5-bromo-4-chloro-3-indolyl-beta-D-galactoside) according to the procedure of Guarente (1983, in "Methods in Enzymology, Recombinant DNA, Vol. 107, eds. Wu, R. and Grossman, L., p. 181). Yeast colonies producing beta-galactosidase (harbouring pEHB11) develop a blue/green colour which is not apparent in those colonies lacking pEHB11. Thus it can be shown by means of a simple plate assay that brewing yeast transformed with the plasmid pEHB11 is capable of producing enzymatically active beta-galactosidase.

The yeast strain NCYC 240 (pEHB11) has been deposited at the National Collection of Yeast Cultures, Colney Lane, Norwich NR4 7AU, United Kingdom on December 12th 1984 under No. NCYC 1547.

Induction of beta-galactosidase production in brewing yeast

Brewing yeast strains NCYC240 (pEHB11) and NCYC240 (pET13:1) described in the aforesaid Patent Application were grown in aerobic shake flask culture (NEP medium plus 2% glucose and 0.2mM $\text{CuSO}_4 \cdot 7\text{H}_2\text{O}$) at 28°C. Late stationary phase cells were harvested from the culture medium and assayed for

- 16 -

beta-galactosidase activity as described by Miller (In "Experiments in Molecular Genetics" ed. Miller, J.H., Cold Spring Harbor Laboratory, Cold Spring Harbor, New York, 1972).

5 Cells were washed x 2 in distilled water and resuspended in Z buffer (16.1g/l $\text{Na}_2\text{HPO}_4 \cdot 7\text{H}_2\text{O}$, 5.5g/l $\text{NaH}_2\text{PO}_4 \cdot \text{H}_2\text{O}$, 0.75 g/l KCl, 0.246 g/l $\text{MgSO}_4 \cdot 7\text{H}_2\text{O}$, 2.7 ml/l 2-mercaptoethanol). The absorbance at 600nm was determined and the cells were permeabilized
10 by the addition of 3 drops of chloroform, 2 drops of 0.1% sodium dodecyl sulphate (SDS) and vortexing for 10 sec. To 1 ml of permeabilized cells in Z buffer was added 0.2 ml of O-nitrophenol-galactoside (ONPG) (4 mg/ml in phosphate buffer, pH 7) and the reaction
15 mixture was incubated at 28°C. The reaction was stopped by the addition of 0.5 ml 1M Na_2CO_3 , cell debris removed, and the absorbance at 420 nm determined. Beta-Galactosidase units were calculated as described by Miller (1972).

20 Assays revealed that NCYC 240 (pET13:1) did not possess any endogenous beta-galactosidase activity, whereas NCYC 240 (pEHB11) produced approximately 1.05 units of beta-galactosidase. When cells of NCYC 240 (pEHB11) were resuspended in 2 volumes of 2%
25 galactose solution and incubated at 28°C for a prolonged period of time, beta-galactosidase activity was induced to a considerably higher level. Thus, after five hours induction, 135 units of beta-galactosidase were obtained, without any
30 increase in cell number, whereas after 23 hours induction and a 2 fold increase in cell number 4154 units of beta-galactosidase were obtained. When either strain NCYC 240 or NCYC 240 (pET13:1) were subjected to the same treatment there was no
35 detectable beta-galactosidase.

- 17 -

Galactose induction of beta-galactosidase production in brewing yeast following a beer fermentation

Plasmid pEHB11 was transformed, as described previously, into a proprietary strain of lager yeast, BB10.1, BB10.1 (pEHB11) and NCYC 240 (pEHB11) were grown in NEP medium plus 2% glucose and 0.2mM $\text{CuSO}_4 \cdot 7\text{H}_2\text{O}$ at 28°C, yeast were harvested
5 and pitched (inoculated) into air saturated brewers wort. Fermentation proceeded anaerobically at 12°C until there was no further reduction in the specific gravity of the beer. Fermentation profiles were closely monitored and direct comparisons were made with fermentations performed
10 on the same wort with the parental brewing yeast, NCYC 240 and BB10.1 which had not been transformed with plasmid pEHB11. In all cases the genetically modified yeast fermented the wort at the same rate and to the same degree of attenuation as the parental yeast strains. BB10.1
15 (pEHB11) and NCYC 240 (pEHB11) were harvested from their respective beers by centrifugation and following two washes in water were assayed for beta-galactosidase activity. Neither yeast strain produced in excess of 1.0 units of beta-galactosidase when assayed in this manner. However,
20 following resuspension in 2% w/v galactose significant quantities of beta-galactosidase were obtained. Optimal conditions for galactose induction of beta-galactosidase activity were defined as follows: (i) 2-3% w/v galactose, (ii) minimal salts medium (1.7 g/l yeast nitrogen base
25 without amino acids and ammonium sulphate, 5 g/l ammonium sulphate, 2.5% w/v casamino acids), (iii) cell density of 0.1 to 30%, preferably 10%, w/v (wet yeast pellet/induction medium) (iv) presence of molecular oxygen. Employment of these conditions resulted in the routine production of 2000-1200 units of
30 beta-galactosidase in NCYC 240 (pEHB11) and BB10.1 (pEHB11) following 24 hours residence in induction medium.

Strain NCYC 240 (pEHB11) was further evaluated under beer production conditions. In this case the yeast was used to ferment an all malt ale wort in a five-barrel (5 X 163.7 litres)
35 experimental brewery. The beer produced was conditioned, fined and packaged into bottle, after which it was compared

with a control beer fermented by the parental yeast
NCYC 240, produced under identical conditions. Qualitative
organoleptic analysis did not reveal any significant
difference between the two products. Thus it is apparent
5 that brewing yeast can be successfully genetically modified
such that they are capable of producing significant
quantities of heterologous protein following a post-
fermentation induction, without adversely influencing the
ability of the yeast to produce the primary beer product.

10

EXAMPLE IIProduction of Human Serum Albumin protein in Brewing Yeast

The cloning of the Human Serum Albumin (HSA) cDNA
was carried out using a specific oligonucleotide primer
(see Baralle, F.E., 1977, Cell, 10, 549-558; Noyes, B.E.
15 etal, 1979, Proceedings of the National Academy of Science,
USA, 76, 1770-1774; Hudson, P. etal, 1981, Nature, 291,
127-131). By selecting a favourable region of the known
amino acid sequence of the HSA protein (Dayhoff, M.O., 1976,
Atlas of Protein Sequences and Structures Nat. Biomed. Res.
20 Foundation Washington) it was possible to predict from the
genetic code eight 14 long oligonucleotides, one of which
should be exactly complementary to the HSA messenger RNA
(mRNA) (see Figure 2 of the accompanying drawings). The
oligonucleotides were synthesized simultaneously (by the
25 method of Wallace, R.B., 1981, Nucleic Acids Research, 9,
879-894) using the solid phase phosphotriester method
developed by Gait, M.K., etal, (1980, Nucleic Acids
Research, 8, 1081-1096). This mixture of synthetic
oligonucleotides was used as a primer for cDNA synthesis
30 using human liver RNA as a template (see Baralle, F.E., 1977,
Cell, 12, 1085-1095). The synthesized cDNA was
fractionated on a denaturing gel and an appropriately sized
band was eluted. This single stranded cDNA was then
converted to double strand by the 'loop back' reaction with
35 Klenow DNA polymerase (see Wickens, M.P., etal, 1978,
Journal of Biological Chemistry, 253, 2483-2495). The

resulting double stranded cDNA was digested with IaqI and ligated to M13mp9 vector which had been AccI-restricted and alkaline phosphatase-treated and the ligation mixture was transformed into the E.coli strain JM101 (Messing, J. and 5 Vieira, J., 1981, Analects, 9. (8), 1). The DNA sequence analysis (determined by the method of Sanger, F. etal, 1980, Journal of Molecular Biology, 143, 161-178) of a sample of the recombinant phage allowed the identification of two clones herein designated M13ALB1 and M13ALB2 10 (Fig. 3). These clones included the DNA sequence of the HSA cDNA between nucleotides 144-692 (M13ALB1) and 692-955 (M13ALB2) (Fig. 3).

A cDNA library was prepared synthesizing cDNA with total liver mRNA as template and using oligo thymine dT12-18 15 as primer. The cDNA's were converted to double strands as described previously and the single strand hairpin loop structure was digested with S1 nuclease (Efstratiadis, A. etal, 1976, Cell, 7, 279-288). The products were purified on a Sephacryl S 300 column and the eventual 5' overhanging 20 ends of the cDNA were repaired by "filling in" with the Klenow fragment of DNA polymerase I. The cDNA molecules at this stage were predominantly blunt ended so they were ligated to the PvuII site of pAT153PvuII8 (previously treated with alkaline phosphatase to avoid its circularization) 25 (Anson, D. et.al. The EMBO Journal, 3, 1984, pp 1053-1064) and transformed into E.coli strain MC1061 (Casadaban, M.T., & Cohen, SN., 1980 Journal of Molecular Biology, 138, 179-207) or another appropriate strain. Approximately 10,000 recombinant colonies were produced from 10 μ g of mRNA. 30 The cDNA in these colonies was screened for HSA DNA sequences using radioactive probes prepared from M13ALB1 and M1ALB2 by nick translation (Rigby, P.W.J. etal, 1977, Journal of Molecular Biology, 113, 237-251). Colonies of E.coli strain MC1061 harbouring recombinant cDNA clones 35 possessing DNA sequence homology with the HSA gene were isolated as described by Baralle, F.E. etal (1980, Nucleic

- 20 -

Acids Research, 8, 4393-4404). Full length cDNA clones were characterised by DNA sequence analysis (Maxam, A.M. and Gilbert, W., 1980, Methods in Enzymology, 65, 499-560; Sanger, F. et al, 1980, Journal of Molecular Biology, 143, 5 161-178) and were found to include the entire HSA cDNA gene (Fig. 3). The 5' non-coding region and the signal peptide sequence of the full length HSA cDNA were excised in the way shown in Figure 4 to produce plasmid pAT135ALB.

Construction of a MET-HSA cDNA

10 The strategy for the construction of a MET-HSA cDNA employed generally known techniques: a summary is shown in Figure 5. The 1843 base pair BamHI fragment from pAT153 ALB was isolated, and made flush ended by nuclease S1 treatment (Maniatis et al, 1982, Molecular Cloning: A Laboratory 15 Manual, Cold Spring Harbor, USA) at the XbaI site of M13mpl9 (Messing, 1983, Methods in Enzymology, Recombinant, 101, 20-78), the latter having been similarly made flush ended by nuclease S1 treatment. Following transfection of E.coli 20 JM101, lysates were prepared from several plaques and single stranded (SS) DNA isolated from the mature bacteriophage particles. Subsequent to DNA sequence analysis (Sanger, 1977 et al, Proc. Nat. Acad. Sci., USA, 74, 5463) the recombinant M13mpl9.7 was identified. Double stranded (RF) DNA was prepared and cleaved at the newly created unique 25 XhoI site by treatment with the latter restriction endonuclease, followed by S1 nuclease digestion to remove the 5' single strand extensions.

These manipulations served to expose the first codon (GAT) for the mature, native polypeptide sequence. Next, a synthetic oligonucleotide whose 5' ends were 30 unphosphorylated was inserted at the modified XhoI site. As previously, recombinants were analysed directly by DNA sequence determination following transfection and SS DNA preparation. The sequence of the relevant portions of one such recombinant, M13 mp 19.7 met/9, is shown (Figure 5). This 35 deviates from the expected sequence, also shown in Figure 5; this deviation is most probably due to secondary

- 21 -

structure formation about the double BamHI site and subsequent excision of the non-bonded regions of the intrastrand partial duplex. These deviations are inconsequential since the sole purpose for the linker insertion was to introduce an initiation codon (ATG) and a BamHI site immediately upstream from the HSA coding sequence, which was achieved. For convenience a further BamHI site was introduced 3' to the MET-HSA coding sequence in M13mp19.7 met/9. In this instance RF DNA of the latter molecule was cleaved at the unique SalI site, originating in the cloning linker of M13mp19, and this species made flush ended by treatment with E.coli DNA polymerase I (the large fragment or "Klenow" fragment (Maniatis *et al*, 1982, Molecular Cloning: A Laboratory Manual, Cold Spring Harbor, USA)). The same linker used above was inserted at this modified site. Following RF DNA preparation and BamHI digestion a suitable recombinant clone was identified and this was designated M13mp19.7 met/9.1. A single BamHI fragment carrying the full length MET-HSA cDNA gene was subsequently cloned in the single BamHI site of the E.coli vector pBR322 (Bolivar *et al*, 1977, Gene, 2, 95-113) to derive a plasmid designated pEK113 (Figure 6). Plasmid pEK113 was transformed into the E.coli strain MC1061 (Casadaban & Cohen, 1980, Journal of Molecular Biology, 138, 179-207) which was deposited in the National Collection of Industrial Bacteria (NCIB) Torry Research Station, PO Box 31, 135, Abbey Road, Aberdeen, Scotland, AB9 8DG on April 3rd 1986 and has the accession number NCIB 12242.

The Inducible Expression of HSA-like Protein in Brewing Yeast

In order to produce HSA-like protein in brewing yeast by an inducible gene expression system it is necessary to fuse the MET-HSA cDNA coding sequence to an appropriate expression signal. The GAL10-CYC1 hybrid promoter which controls the galactose inducible expression of the E.coli lacZ gene (β -galactosidase production) has general application as a system for mediating the galactose

- 22 -

inducible expression of heteroloquous genes in brewing yeast. To take advantage of this, the MET-HSA cDNA is fused to the GAL10-CYC1 promoter present in plasmid pEHB11. Plasmid pEHB11 is digested with the restriction endonuclease BamHI and the BamHI fragment carrying the MET-HSA cDNA from pEK113 is inserted. The orientation of insertion is determined by characterising the recombinant plasmids generated with restriction endonucleases and separating the fragments thus formed by agarose gel electrophoresis. A recombinant plasmid is isolated in which the 5' MET-HSA cDNA has fused with the 3' GAL10-CYC1 hybrid promoter, such that following DNA sequence analysis (Maxam, A. M. and Gilbert, W., 1980, Methods in Enzymology, 65, 499-560) the junction of the fusion has the DNA sequence 5' ... TTAATA ATG ACC GGA TCC ATG GAT ... 3' (See Figure 7). This plasmid is designated pEHB11-MET-HSA and may be introduced into brewing yeast strains NCYC 240 and BB10.1 by transformation and selection for copper resistance as described previously. Brewing yeast strains transformed with plasmid pEHB11-MET-HSA are expected to produce under appropriate conditions an HSA-like protein consisting of five additional amino acids prior to the first N terminal amino acid of mature HSA (N-methionine, threonine, glycine, serine, methionine-HSA-C).

Strain NCYC 240 and BB10.1 harbouring pEHB11-MET-HSA may be grown to stationary phase in NEP glucose medium supplemented with 0.2mM $\text{CuSO}_4 \cdot 7\text{H}_2\text{O}$. Cells are then harvested by centrifugation and washed in water before resuspending for 24 hours under optimal conditions for galactose induction of gene expression, described previously. Crude cell free extracts of induced (plus galactose) and uninduced (without galactose) cultures are prepared by disrupting the cells on a Braun homogeniser in 0.1M sodium phosphate pH 7.5, 1mM phenylmethylsulfonyl fluoride and 5mM 2-mercaptoethanol. Glass beads and cell debris are removed by centrifugation (2000 x g for 2 minutes) and the

- 23 -

supernatant is clarified by recentrifugation (8000 x g for 10 minutes). The resultant cell extracts are assayed for the presence of Human Serum Albumin protein by SDS: polyacrylamide gel electrophoresis followed by Western blotting (see Mellor, J. et al, 1985, Gene, 33, p215). The results of this assay indicate that those cultures which had been induced in the presence of galactose contained significant quantities of intracellular Human Serum Albumin-like protein, whereas uninduced cultures do not.

10 A similar galactose induction of Human Serum Albumin-like protein production can be obtained with both NCYC 240 (pEHB11-MET-HSA) and BB10.1 (pEHB11-MET-HSA) harvested from a beer fermentation in which the yeast strain has first been used to ferment brewers wort under anaerobic
15 fermentative conditions. Yeast harvested at the end of the beer fermentation does not contain detectable quantities of Human Serum Albumin-like protein, whereas following 24 hours of galactose induction significant amounts of protein can be detected. It is further noted that brewing yeasts
20 genetically modified in the manner described are capable of fermenting brewers wort at the same rate and to the same degree of attenuation as their unmodified parental counterparts; beers thus produced are indistinguishable from controls on organoleptic analysis.

25 The Inducible Expression of MET-HSA in Brewing Yeast

The GAL10-CYC1-HSA fusion plasmid pEHB11-MET-HSA can be shown to produce an HSA-like protein in brewing yeast following post-fermentation induction in galactose induction medium. This protein is described as HSA-like since it
30 possesses five extra amino acids at the N-terminus, as described previously. In order to produce a more "authentic" HSA protein it is necessary to construct a GAL10-CYC1 hybrid promoter transcriptional fusion with the MET-HSA cDNA in which the 5' translational ATG codon (methionine) is
35 supplied by the MET-HSA cDNA. For this purpose the ATG⁻ GAL10-CYC1 promoter carried by the publicly available

- 24 -

plasmid G2 can be used (Guarente, 1983, Methods in Enzymology, Recombinant DNA, 101, 181-191). Plasmid G2 is digested with the restriction endonuclease BamHI and ligated with ~1.8 kilo base-pair MET-HSA cDNA BamHI fragment from pEK113. The orientation of insertion is confirmed by restriction endonuclease digestion and shows that the 5' MET-HSA cDNA is fused to the 3' GAL10-CYC1 ATG promoter. This plasmid is designated G2 MET-HSA (see Figure 8). Plasmid G2 MET-HSA carries an E.coli plasmid origin of DNA replication, the β -lactamase gene conferring ampicillin resistance in E.coli, the 2 μ m origin of DNA replication of yeast, the URA-3 gene of yeast (facilitating selection by complementation of ura-3 auxotrophs in laboratory yeast) and the GAL10-CYC1-MET-HSA fusion cassette. Transcription of the MET-HSA gene is expected to result in the synthesis of a messenger RNA which will initiate translation at the first ATG in the message, and this ATG is provided by the MET-HSA gene.

In order to regulate the expression of the MET-HSA gene in brewing yeast, and thus the production of an "authentic" recombinant Human Serum Albumin protein, it is necessary to fuse the GAL10-CYC1-MET-HSA expression unit to the CUP-1 gene. This is accomplished by digesting plasmid G2-MET-HSA with the restriction endonuclease HindIII, which cleaves upstream (5') of the URA-3 gene and downstream (3') of the MET-HSA coding sequence (see Figure 8), and subcloning this fragment into the HindIII site of pET13:1 to form plasmid designated pET13:1-MET-HSA (Figure 8).

Plasmid pET13:1-MET-HSA is subsequently transformed into the brewing yeast strains NCYC 240 and BB10.1 by the methods described previously. Brewing yeast strains harbouring plasmid pET13:1-MET-HSA are grown to stationary phase in NEP glucose medium supplemented with 0.2m. $\text{CuSO}_4 \cdot 7\text{H}_2\text{O}$. Cells are harvested and processed prior to the galactose induction of gene expression, as described previously. Cell extracts were prepared and assayed

- 25 -

for the presence of Human Serum Albumin protein, as described previously. In all cases brewing yeast strains harbouring the GAL10-CYC1-MET-HSA (pET13:1-MET-HSA) produced significant quantities of Human Serum Albumin protein.

- 5 When the same strains are grown on brewers wort under anaerobic conditions, followed by induction of gene expression and HSA assay as described previously, significant quantities of Human Serum Albumin can be detected. The yeast harvested at the end of a beer
- 10 fermentation does not possess any detectable Human Serum Albumin protein prior to galactose induction.

- 26 -

CLAIMS

1. Process for the production of ethanol and a protein or peptide which is heterologous to yeast which comprises fermenting an aqueous carbohydrate-containing medium with a yeast strain which has been genetically modified to be capable of expressing a heterologous protein or peptide under conditions such that the yeast multiplies but no expression of the said heterologous protein or peptide takes place, recovering the ethanol so formed, inducing expression of the said protein or peptide by the yeast, and obtaining the said heterologous protein or peptide therefrom.
2. Process according to claim 1 in which the said yeast contains a plasmid having the GAL 10-CYC1 hybrid promoter and expression of the said protein or peptide is induced by exposing the said multiplied yeast to galactose.
3. Protein according to claim 1 or 2 in which the said protein or peptide is human serum albumin or a human serum albumin-like protein.
4. Process according to any of claims 1 to 3 in which the ethanol is recovered in the form of an aqueous potable liquid which is substantially free from yeast and which contains substantially all the water and ethanol of the said fermented medium.
5. Process according to any of claims 1 to 3 in which the ethanol is recovered from the said fermented medium in the form of an ethanolic distillate.
6. Process according to claim 4 in which the aqueous carbohydrate-containing medium contains maltose as the major sugar present.
7. Process according to claim 6 in which the aqueous carbohydrate-containing medium is a barley malt-based beer wort.
8. Process according to claim 4, 6 or 7 in which the fermentation is effected at 8 to 25^{°C}.

- 27 -

9. Process according to claim 5 in which the aqueous carbohydrate-containing medium is a fermentation medium for the production of potable distilled ethanol or power ethanol.

5 10. Process according to claim 9 in which the said medium is based on grain, potatoes, cassava, sugar cane, sugar beet or a lignocellulosic material optionally pretreated to convert cellulose and/or starch therein into fermentable sugars.

10 11. Process according to any one of claims 1 to 10 in which the fermentation is a substantially anaerobic fermentation.

15 12. Process according to any one of claims 1 to 11 in which the yeast used is a genetically engineered modification of an industrial strain of Saccharomyces cerevisiae, or S. carlsbergensis.

1/11

Fig.1. Construction of plasmid pEHB II

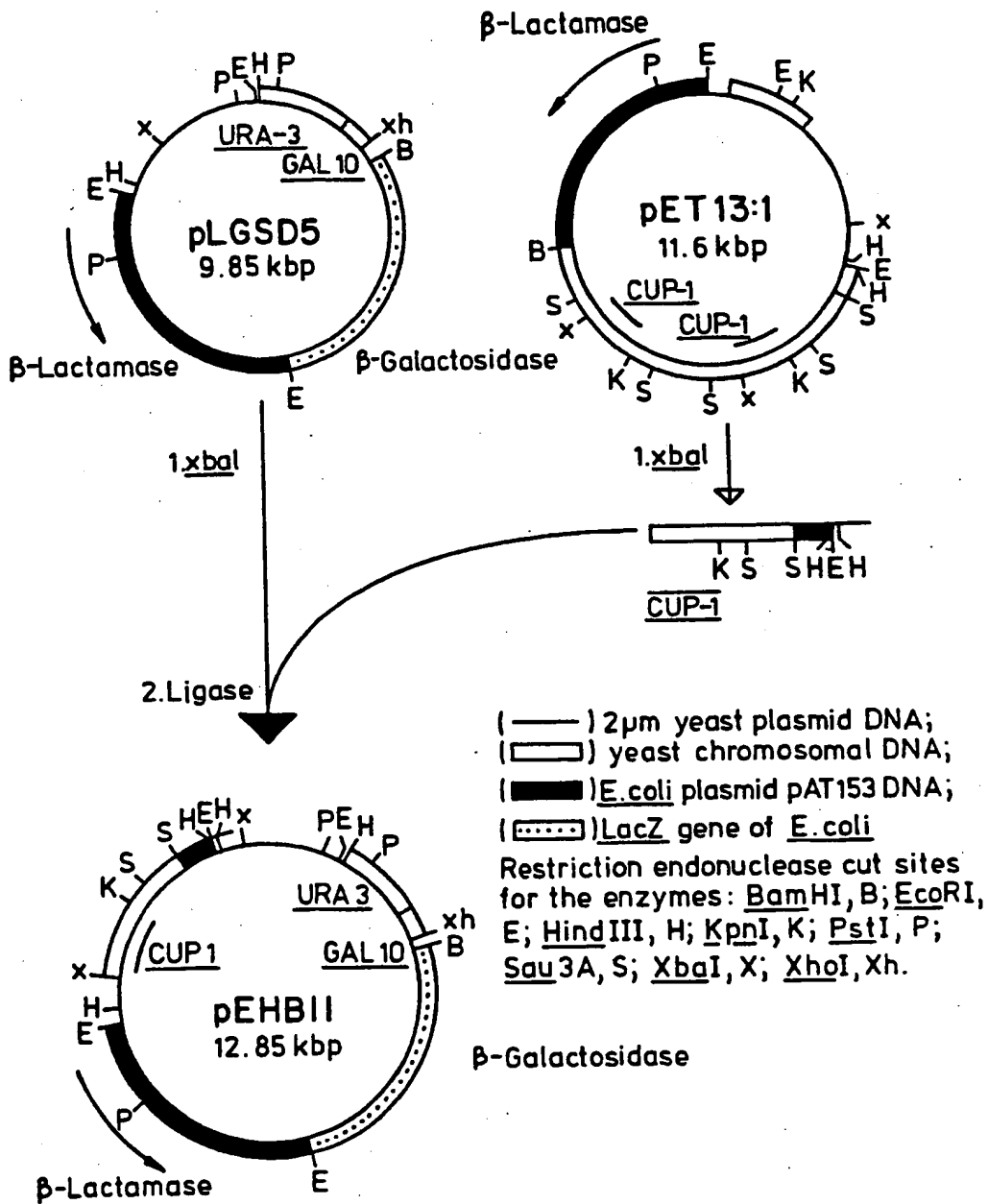

2/11

Fig. 2. Oligonucleotide sequence of the HSA primer

HSA
 295 296 297 298 299
 Asn Asp Glu Met Pro
 5' AAY GAY GAR AUG CC N 3'
 3' TTR CTR CTY TAC GG I 5'
 + Predicted Primer:
 * 14 long oligonucleotide primer:
 used for HSA
 TTA CTA CTT TAC GG
 G G C

* From the genetic code an mRNA sequence can be predicted with 3 ambiguities [R indicates a purine (adenine or guanine), Y indicates a pyrimidine (thymine or cytosine)]

* The primer sequence was designed to be complementary to the mRNA region coding for amino acids 295-298. Hence a mixture of the 8 possible complementary oligonucleotides was simultaneously synthesized.

3/11

Fig. 3. DNA Sequence of the Human serum Albumin c DNA gene

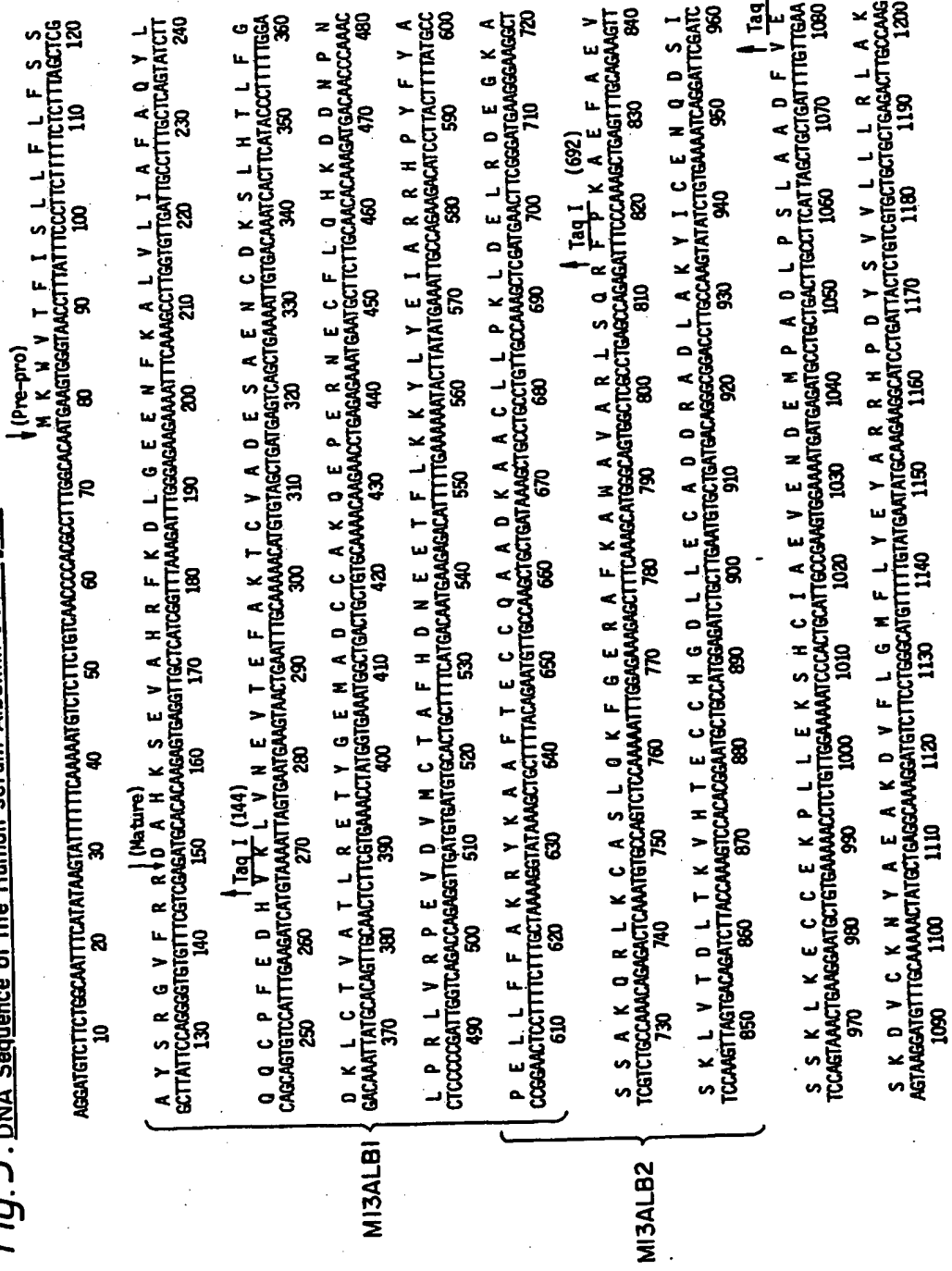

Fig.3.(Contd.)

T Y E T T L E K C C A A A D P H E C Y A K V F D E F K P L V E E P Q N L I K Q N
 ACATATGAACCACCTCTAGAGAGTGTGCGCTGCAGATCCCTCATGATGCTATCCCAAGTGTTCGATGATTTAAGCTCTTGTGAGAGCCTCAGAATTTAATCAAGCAAAAC
 1210 1220 1230 1240 1250 1260 1270 1280 1290 1300 1310 1320

C E L F K Q L G E Y K F Q N A L L V R Y T K K V P Q V S T P T L L V E V S R R N L G
 TGTAGCTTTTAAAGCAGCTTGGAGATGCAAAATCCAGATGCGCTATTAGTTCGACAGACTATCTATCCGTGCTGACAGCTATGTTGATGAGAGTCTCAAGAACTAGGA
 1330 1340 1350 1360 1370 1380 1390 1400 1410 1420 1430 1440

K V G S K C C K H P E A K R M P C A E D Y L S V V L N Q L C V L H E K T P V S D
 AAGTGGCAGCAAAATGTTGTAACATCCCTGABGCAAAAGAAATGCGCTGTCAGAGACTATCTATCCGTGCTGACAGCTATGTTGATGAGAGTCTCAAGAACTAGGA
 1450 1460 1470 1480 1490 1500 1510 1520 1530 1540 1550 1560

R V T K C C T E S L V N R R P C F S A L E V D E T Y V P K E F N A E T F T F H A
 AGATCACAANAATGCTGCACAGATCCTGGTGAACAGCGACCATGCTTTTCCAGCTTGGAGTCTGAAACATACGTTCCCAAGAGATTTAATGCTGAACATTCACCTCCATGCA
 1570 1580 1590 1600 1610 1620 1630 1640 1650 1660 1670 1680

D I C T L S E K E R Q I K K Q T A L V E L V K K P K A T K E Q L K A V M D D F
 GATATGCACACTTTCTGAGAGGAGACAAATCAAGAAACAACCTGCCTTTGAGCTTGTGAACACAGCCCAAGGCAACAAAGAGCAACTGAAAGCTGTTATGAGATGATTC
 1690 1700 1710 1720 1730 1740 1750 1760 1770 1780 1790 1800

A A F V E K C K A D D K E T C F A E E G K K L V A A S O A A L G L *
 GCAGCTTTGTAGAGAGTCTGCAAGCTGACGATAGAGAGCTGCTTTGCCGAGGAGGTAAGAAATTTGTTGCTCAAGCTCAAGCTGCTTAGGCTTATAACATCTACATTTAAAA
 1810 1820 1830 1840 1850 1860 1870 1880 1890 1900 1910 1920

GCATTCAGCTTACCATGSAATAGAGAGAAATGAGATCAAAAGCTTATTCACTGTTTTTTTTGTTGTTAAGGCAACACCCCTGCTAATAAACATAAATTTCTTAAT
 1930 1940 1950 1960 1970 1980 1990 2000 2010 2020 2030 2040

CAITTTGCTTTTCTGCTGCTCAATTAATAAAAAATGSAAGATCTAATAAGTGTACAGCACTGTTATTTTCAAGAGTGTGTGCTATCCGAAAAATCTGTAGGTTCTGTG
 2050 2060 2070 2080 2090 2100 2110 2120 2130 2140 2150 2160

GAAGTCCAGTGTCTCTTTTCCACTCGGTAGAGGATTTCTAGTTTCTGTTGAGGCTAATAATAACTACTAATCTTCTTAAGTTAAAAAA 2
 2170 2180 2190 2200 2210 2220 2230 2240 2250 2260 2270 2280 2290 2300 2310 2320 2330 2340 2350 2360 2370 2380 2390 2400 2410 2420 2430 2440 2450 2460 2470 2480 2490 2500 2510 2520 2530 2540 2550 2560 2570 2580 2590 2600 2610 2620 2630 2640 2650 2660 2670 2680 2690 2700 2710 2720 2730 2740 2750 2760 2770 2780 2790 2800 2810 2820 2830 2840 2850 2860 2870 2880 2890 2900 2910 2920 2930 2940 2950 2960 2970 2980 2990 3000 3010 3020 3030 3040 3050 3060 3070 3080 3090 3100 3110 3120 3130 3140 3150 3160 3170 3180 3190 3200 3210 3220 3230 3240 3250 3260 3270 3280 3290 3300 3310 3320 3330 3340 3350 3360 3370 3380 3390 3400 3410 3420 3430 3440 3450 3460 3470 3480 3490 3500 3510 3520 3530 3540 3550 3560 3570 3580 3590 3600 3610 3620 3630 3640 3650 3660 3670 3680 3690 3700 3710 3720 3730 3740 3750 3760 3770 3780 3790 3800 3810 3820 3830 3840 3850 3860 3870 3880 3890 3900 3910 3920 3930 3940 3950 3960 3970 3980 3990 4000 4010 4020 4030 4040 4050 4060 4070 4080 4090 4100 4110 4120 4130 4140 4150 4160 4170 4180 4190 4200 4210 4220 4230 4240 4250 4260 4270 4280 4290 4300 4310 4320 4330 4340 4350 4360 4370 4380 4390 4400 4410 4420 4430 4440 4450 4460 4470 4480 4490 4500 4510 4520 4530 4540 4550 4560 4570 4580 4590 4600 4610 4620 4630 4640 4650 4660 4670 4680 4690 4700 4710 4720 4730 4740 4750 4760 4770 4780 4790 4800 4810 4820 4830 4840 4850 4860 4870 4880 4890 4900 4910 4920 4930 4940 4950 4960 4970 4980 4990 5000 5010 5020 5030 5040 5050 5060 5070 5080 5090 5100 5110 5120 5130 5140 5150 5160 5170 5180 5190 5200 5210 5220 5230 5240 5250 5260 5270 5280 5290 5300 5310 5320 5330 5340 5350 5360 5370 5380 5390 5400 5410 5420 5430 5440 5450 5460 5470 5480 5490 5500 5510 5520 5530 5540 5550 5560 5570 5580 5590 5600 5610 5620 5630 5640 5650 5660 5670 5680 5690 5700 5710 5720 5730 5740 5750 5760 5770 5780 5790 5800 5810 5820 5830 5840 5850 5860 5870 5880 5890 5900 5910 5920 5930 5940 5950 5960 5970 5980 5990 6000 6010 6020 6030 6040 6050 6060 6070 6080 6090 6100 6110 6120 6130 6140 6150 6160 6170 6180 6190 6200 6210 6220 6230 6240 6250 6260 6270 6280 6290 6300 6310 6320 6330 6340 6350 6360 6370 6380 6390 6400 6410 6420 6430 6440 6450 6460 6470 6480 6490 6500 6510 6520 6530 6540 6550 6560 6570 6580 6590 6600 6610 6620 6630 6640 6650 6660 6670 6680 6690 6700 6710 6720 6730 6740 6750 6760 6770 6780 6790 6800 6810 6820 6830 6840 6850 6860 6870 6880 6890 6900 6910 6920 6930 6940 6950 6960 6970 6980 6990 7000 7010 7020 7030 7040 7050 7060 7070 7080 7090 7100 7110 7120 7130 7140 7150 7160 7170 7180 7190 7200 7210 7220 7230 7240 7250 7260 7270 7280 7290 7300 7310 7320 7330 7340 7350 7360 7370 7380 7390 7400 7410 7420 7430 7440 7450 7460 7470 7480 7490 7500 7510 7520 7530 7540 7550 7560 7570 7580 7590 7600 7610 7620 7630 7640 7650 7660 7670 7680 7690 7700 7710 7720 7730 7740 7750 7760 7770 7780 7790 7800 7810 7820 7830 7840 7850 7860 7870 7880 7890 7900 7910 7920 7930 7940 7950 7960 7970 7980 7990 8000 8010 8020 8030 8040 8050 8060 8070 8080 8090 8100 8110 8120 8130 8140 8150 8160 8170 8180 8190 8200 8210 8220 8230 8240 8250 8260 8270 8280 8290 8300 8310 8320 8330 8340 8350 8360 8370 8380 8390 8400 8410 8420 8430 8440 8450 8460 8470 8480 8490 8500 8510 8520 8530 8540 8550 8560 8570 8580 8590 8600 8610 8620 8630 8640 8650 8660 8670 8680 8690 8700 8710 8720 8730 8740 8750 8760 8770 8780 8790 8800 8810 8820 8830 8840 8850 8860 8870 8880 8890 8900 8910 8920 8930 8940 8950 8960 8970 8980 8990 9000 9010 9020 9030 9040 9050 9060 9070 9080 9090 9100 9110 9120 9130 9140 9150 9160 9170 9180 9190 9200 9210 9220 9230 9240 9250 9260 9270 9280 9290 9300 9310 9320 9330 9340 9350 9360 9370 9380 9390 9400 9410 9420 9430 9440 9450 9460 9470 9480 9490 9500 9510 9520 9530 9540 9550 9560 9570 9580 9590 9600 9610 9620 9630 9640 9650 9660 9670 9680 9690 9700 9710 9720 9730 9740 9750 9760 9770 9780 9790 9800 9810 9820 9830 9840 9850 9860 9870 9880 9890 9900 9910 9920 9930 9940 9950 9960 9970 9980 9990 10000

5/11

Fig. 4. 5' Non-coding region modification and signal peptide sequence excision

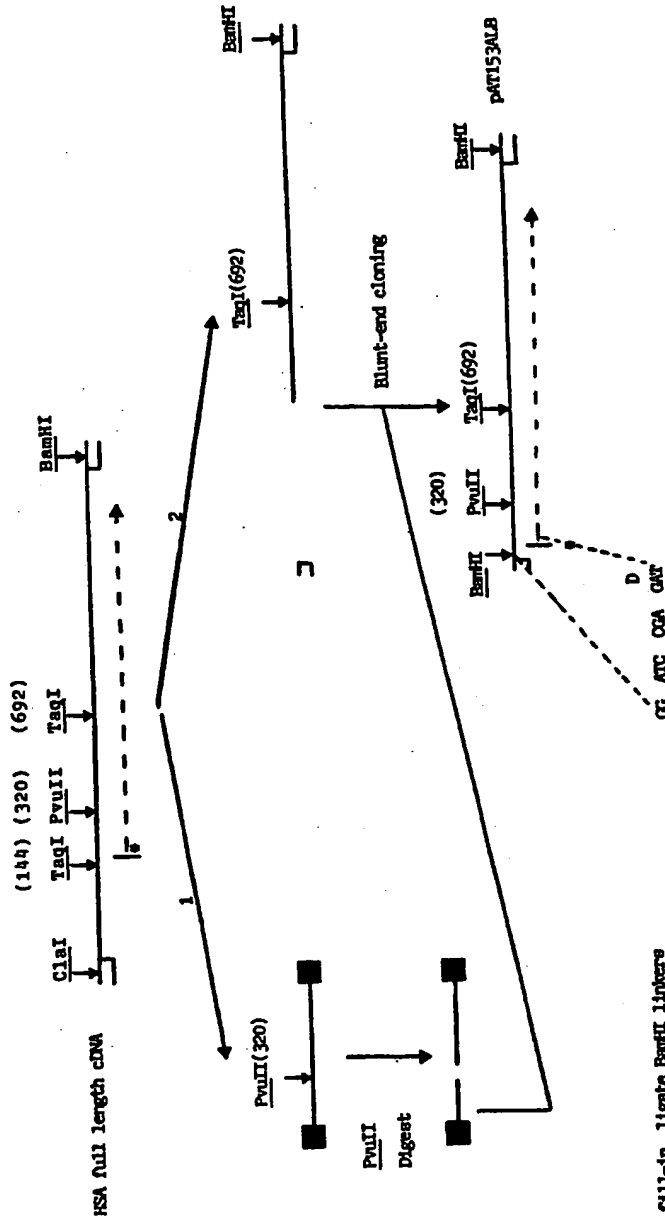

1. TaqI digest, fill-in, ligate BamHI linkers and isolate DNA fragment on a gel

2. PvuII/ClaI double digest, "fill-in"

● Mature HSA

- cDNA

□ pAT153 vector DNA

■ BamHI linkers

6/11

Fig.5. Construction of an "authentic" HSA cDNA (MET-HSA)

M13 mp19 (Messing, J. 1983, Methods in Enzymology, 101, pp20)

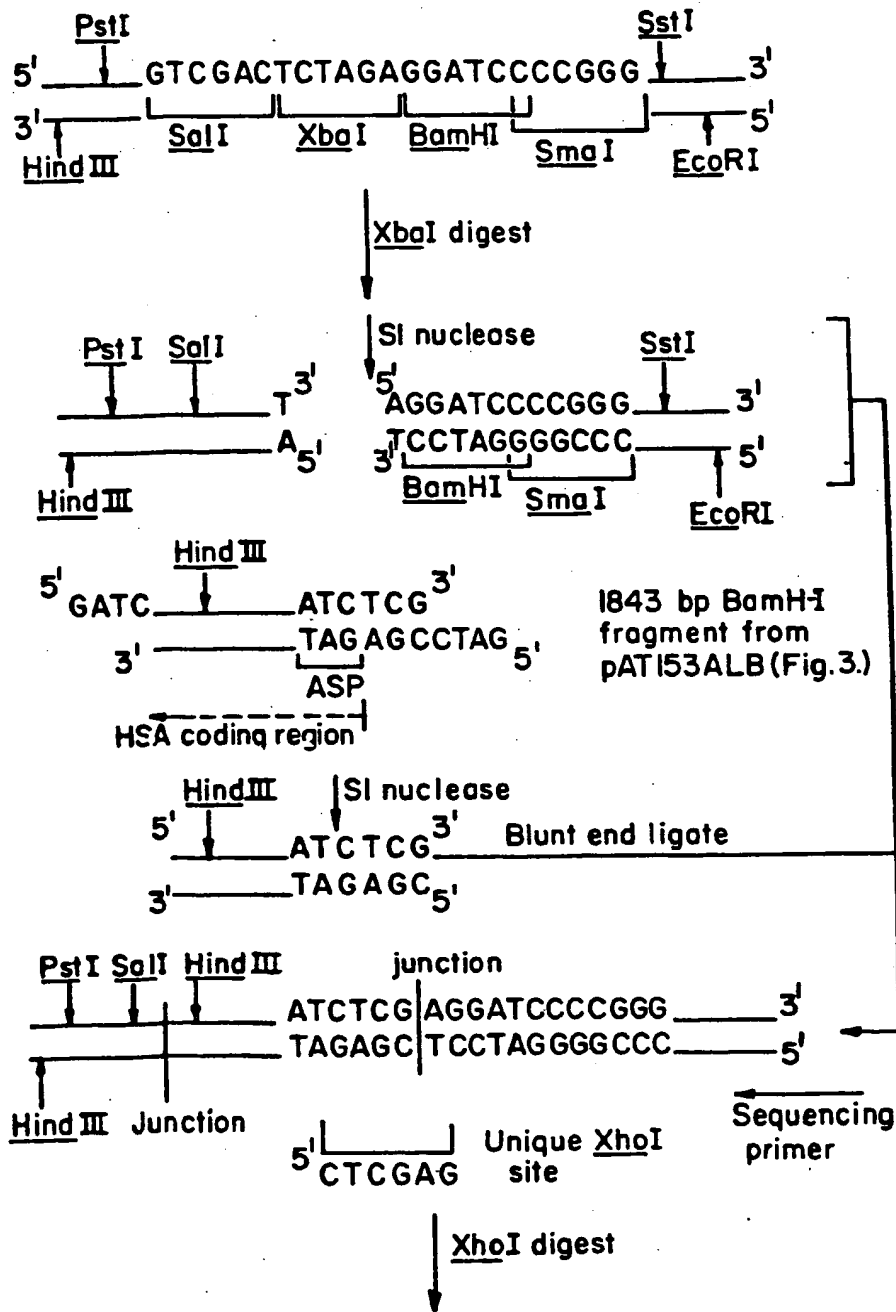

7/11

Fig.5(Contd.)

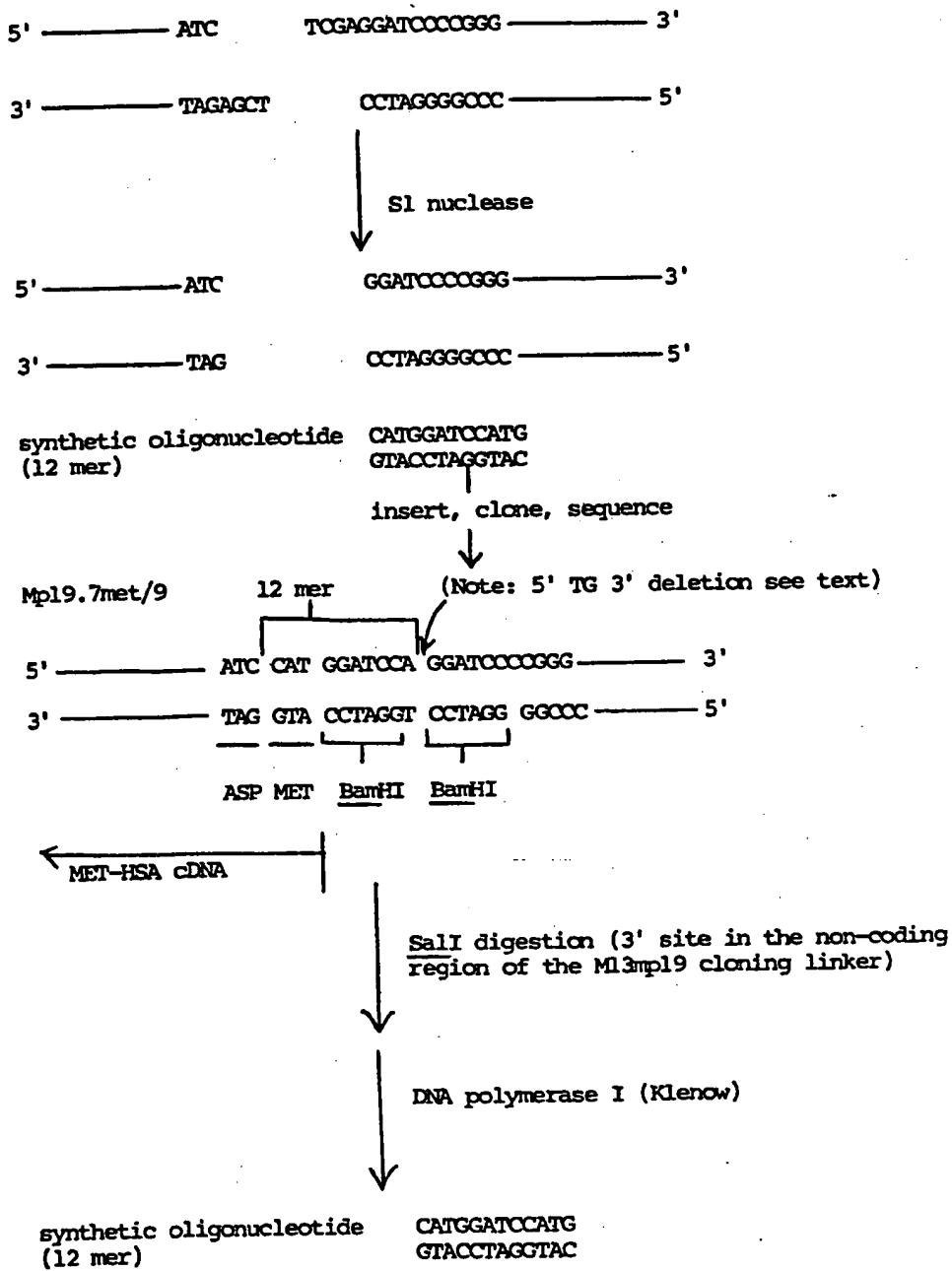

8/11

Fig.5(Contd.)

insert, clone
↓

M13mp19.7met/9.1

12 mer linker

5' --- GTGACATGGATCCATGTCGACTCAG ---
BamHI BamHI
AATCGATGATCCAGGATCC ---

3' --- CAGCTGTACCTAGGTACAGCTGAGTC ---
BamHI
TAGGTACCTAGGTCTGAGG ---

ASP MET

← MET-HSA cDNA

filled in Sall
site

9/11

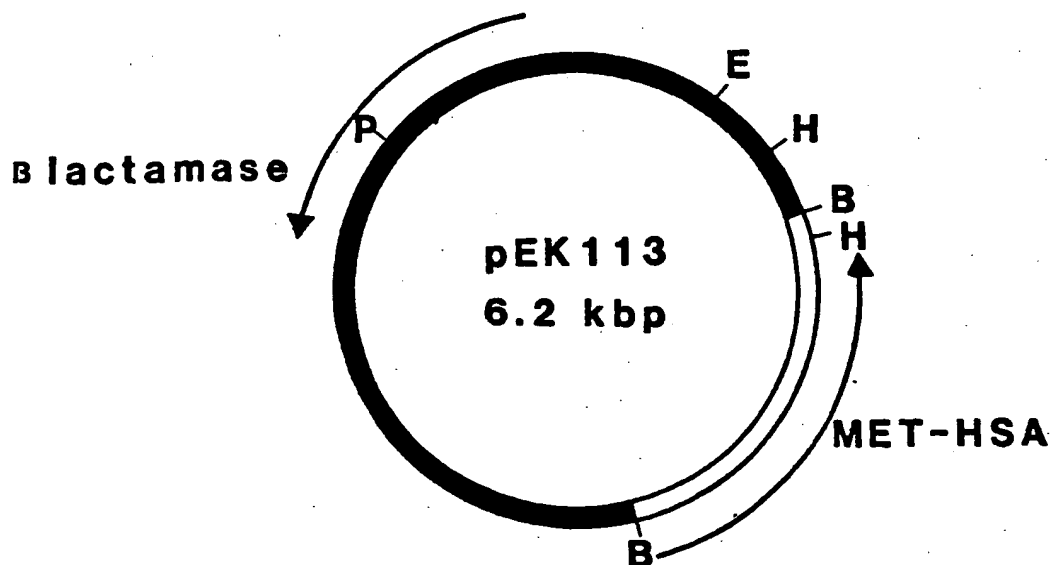
Fig 6 Plasmid pEK113

■ pBR322 DNA

□ MET-HSA DNA

Restriction endonuclease sites
(see Fig. 1)

10/11

**Fig.7 Construction of plasmid
pEHB11 MET-HSA**

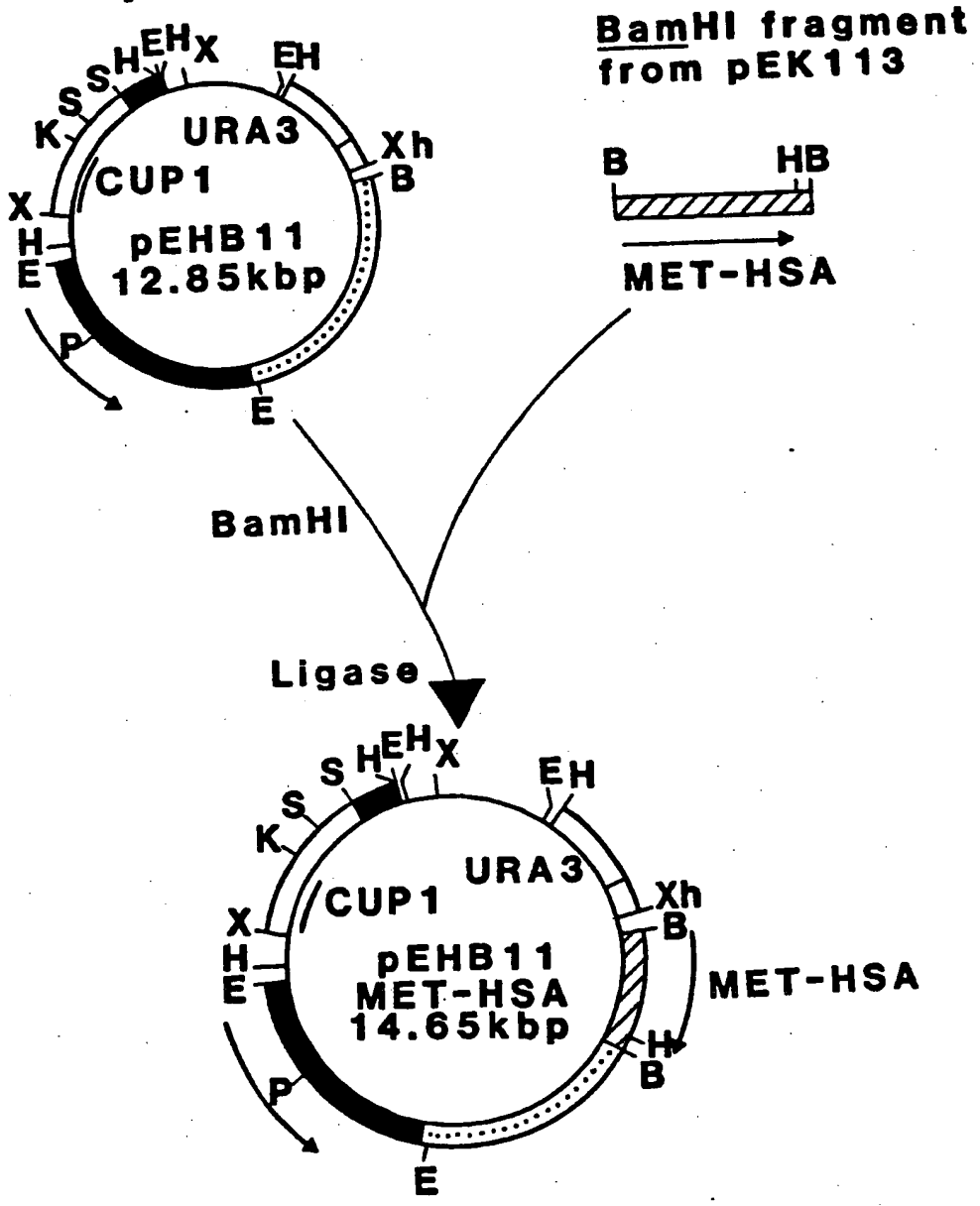

11/11

Fig.8 Construction of plasmid pET13:1-MET-HSA

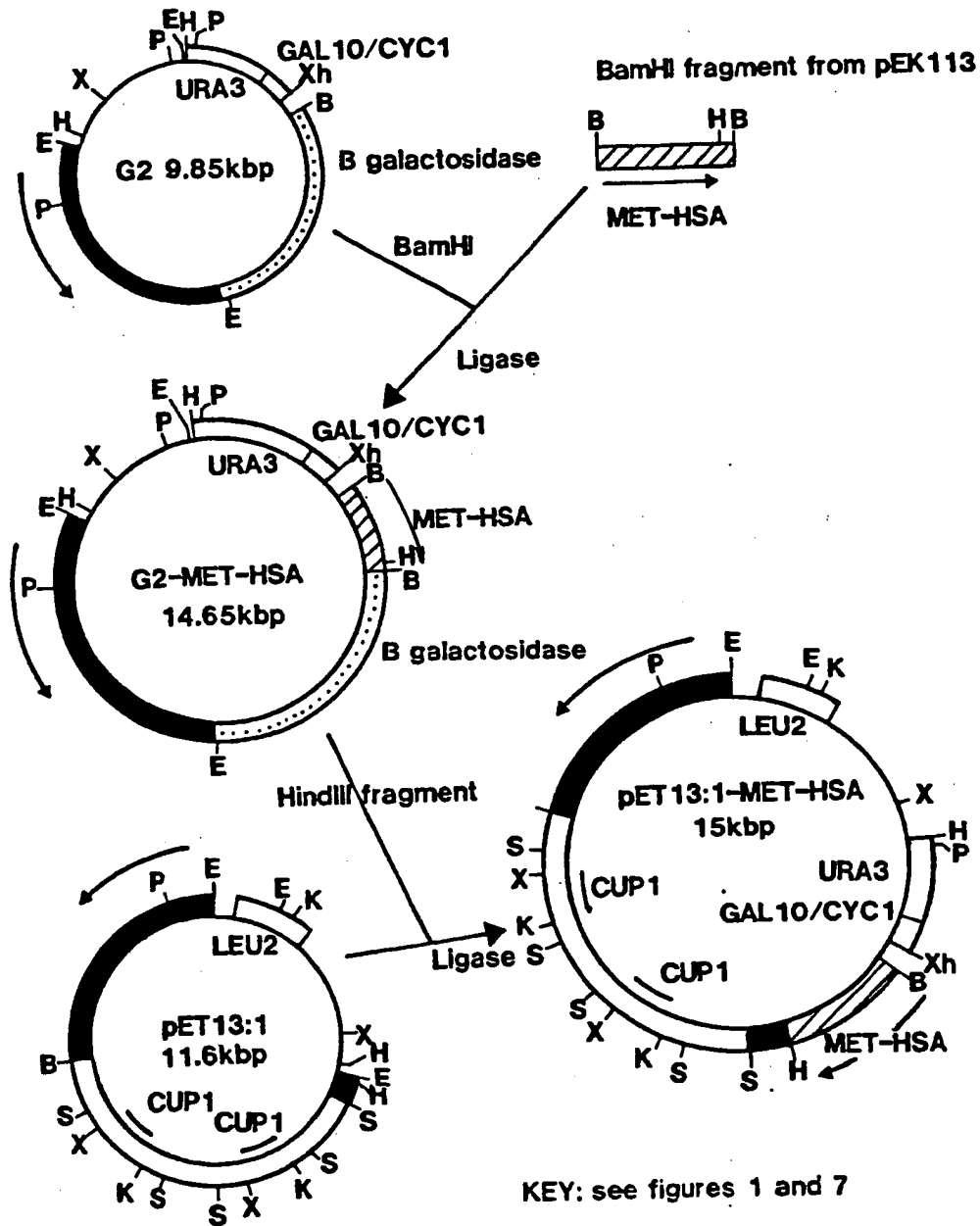

0201239



European Patent
Office

EUROPEAN SEARCH REPORT

Application number

EP 86 30 3039

DOCUMENTS CONSIDERED TO BE RELEVANT			
Category	Citation of document with indication, where appropriate, of relevant passages	Relevant to claim	CLASSIFICATION OF THE APPLICATION (Int. Cl.4)
Y	CHEMICAL ABSTRACTS, vol. 102, no. 19; 13th May 1985, page 135, abstract no. 161231r, Columbus, Ohio, US; R.C.A. Henderson et al.; "The transformation of brewing yeasts with a plasmid containing the gene for copper resistance" * Whole abstract *	1-12	C 12 N 15/00 C 12 C 11/00 C 12 P 21/02 C 12 P 7/06 // C 12 N 9/38
Y	--- BREWERS' GUARDIAN; September 1984, pages 34-37; R.S. TUBB: "Genetic development of yeast strains" * Page 35, column 1, lines 47-49; page 37, column 1; figure 4 *	1-12	
D,P Y	--- EP-A-0 147 198 (BASS PUBLIC LTD. Co.) * Whole document *	1-12	TECHNICAL FIELDS SEARCHED (Int. Cl.4)
D,Y	--- PROC. NATL. ACAD. SCI., vol. 79, December 1982, pages 7410-7414: L. GUARENTE et al.: "A GAL10-CYC1 hybrid yeast promoter identifies the GAL4 regulatory region as an upstream site" * Whole document *	1-12	C 12 N C 12 P C 12 G
A	--- EP-A-0 079 739 (THE UPJOHN COMPANY) * Example 6 *	3	
The present search report has been drawn up for all claims			
Place of search THE HAGUE		Date of completion of the search 11-07-1986	Examiner DESCAMPS J.A.
<p>CATEGORY OF CITED DOCUMENTS</p> <p>X : particularly relevant if taken alone Y : particularly relevant if combined with another document of the same category A : technological background O : non-written disclosure P : intermediate document</p> <p>T : theory or principle underlying the invention E : earlier patent document, but published on, or after the filing date D : document cited in the application L : document cited for other reasons & : member of the same patent family, corresponding document</p>			

0201239



European Patent Office

Application number: 86303039.1

**DECLARATION PURSUANT TO RULE 28, PARAGRAPH 4,
OF THE EUROPEAN PATENT CONVENTION**

The applicant has informed the European Patent Office that, until the publication of the mention of the grant of the European patent or until the date on which the application has been refused or withdrawn or is deemed to be withdrawn, the availability of the micro-organism(s) identified below, referred to in paragraph 3 of Rule 28 of the European Patent Convention, shall be effected only by the issue of a sample to an expert.

IDENTIFICATION OF THE MICRO-ORGANISMS

Accession numbers of the deposits: NCYC 1547
NCIB 12242